



Quality, Reliability, Life

4", 5", 6", 8" Submersible Motor

50Hz



www.prakashpump.com

4" Submersible Motor

PRAKASH

Applications

- Domestic water supply to waterworks
- Irrigation in horticulture and agriculture
- Drip and sprinkler irrigation
- Pressure boosting application
- Water treatment
- Civil and Industrial application

Product feature

- Easily rewindable (wet wound) induction motor with PVC/ Poly wrapped insulated winding.
- Water Lubricated Radial Bearing and High capacity Kingsbury type thrust bearing for 100% maintenance free operation.
- Corrosion resistance stainless steel stator jacket.
- Non-contaminating water filling design.
- High efficiency electrical design for low operation cost.
- Tropical zed design. (Lower winding temperature)
- Cable material according to drinking water regulation.
- All motors prefilled and 100% tested.
- Sand slinger for high performance in sand.

Specification

- 4" NEMA Flange with M8 Stud.
- Water temperature: up to 45° C
- Minimum internal diameter of well: 4" Ø100mm.
- Power Range: 2.2kW to 4kW (Three Phase) 0.37kW to 2.2kW (Single Phase)
- Power Supply: Three Phase 380V-415V ±10%, 50Hz
Single Phase 220V-240V ±10%, 50Hz
- Insulation Class: F
- Protection Class: IP 68
- Max. No of starts per hour: 25
- Direction Of Rotation counter clock wise facing shaft end
- (Rotation Reversible for three phase Motor)
- Standard motor with poly wrapped insulated winding
- Speed: 2900 rpm
- Pole: 2P
- Ambient temp of 30°C with a min. Cooling Flow: 0.37Kw-4.0kw
- Installation position: vertical/Horizontal
- Duty: S1



PSMP100

4 NOS. EQUISPACED
M8x1.25 PITCH
ON P.C.D 76.2 AT 90°

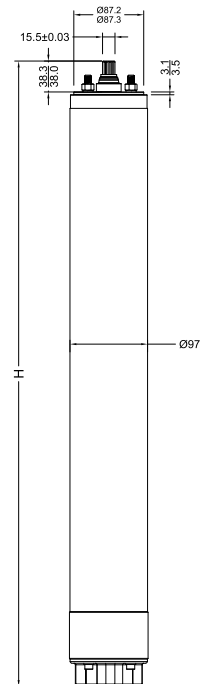
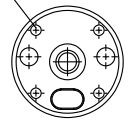

Technical Data, 50Hz, 220V-240V, 2900 RPM

Model	Motor Power		Max. Full Load (A)	Starting Current (A)	Full Load		Method of Start	Max. Down Thrust Load(N)	Torque (Nm)	Starting Torque (Nm)
	kW	HP			Eff. %	Power Factor				
PSMP100-0.5-SP	0.37	0.5	5	16	39	0.89	CSCR	3000	1.2	2.0
PSMP100-0.75-SP	0.55	0.75	6	21	52	0.9	CSCR	3000	1.8	2.9
PSMP100-1.0-SP	0.75	1.0	7.5	26	54	0.9	CSCR	3000	2.5	4.1
PSMP100-1.5-SP	1.1	1.5	10	40	57	0.95	CSCR	3000	3.7	6.1
PSMP100-2.0-SP	1.5	2.0	12	48	60	0.95	CSCR	3000	4.9	8.3
PSMP100-3.0-SP	2.2	3.0	19	66	62	0.95	CSCR	6500	7.4	13.3

Technical Data, 50Hz 380V-415V, 2900 RPM

Model	Motor Power		Max. Full Load (A)	Starting Current (A)	Full Load		Method of Start	Max. Down Thrust Load(N)	Torque (Nm)	Starting Torque (Nm)
	kW	HP			Eff. %	Power Factor				
PSMP100-3.0	2.2	3.0	7	23	69	0.78	D.O.L	6500	7	15
PSMP100-4.0	3.0	4.0	9	31	74	0.73	D.O.L	6500	10	22
PSMP100-5.5	4.0	5.5	10	43	75	0.80	D.O.L	6500	14	31

* D.O.L : Direct On Line

4" Submersible Motor



Packing Dimensions and Weight

Model	Motor Power		Max. Motor Dia	Height (mm)	Net. Weight Kg. (Approx.)	Cable Leadouts	
	kW	HP				Cable Size SQ. MM	Cable Length in meter
PSMP100-3.0S	2.2	3.0	98	720	26	4	3
PSMP100-3.0	2.2	3.0	98	680	23.5	2.5	3
PSMP100-4.0	3.0	4.0	98	720	26	2.5	3
PSMP100-5.5	4.0	5.5	98	780	28.5	2.5	3

Exploded View

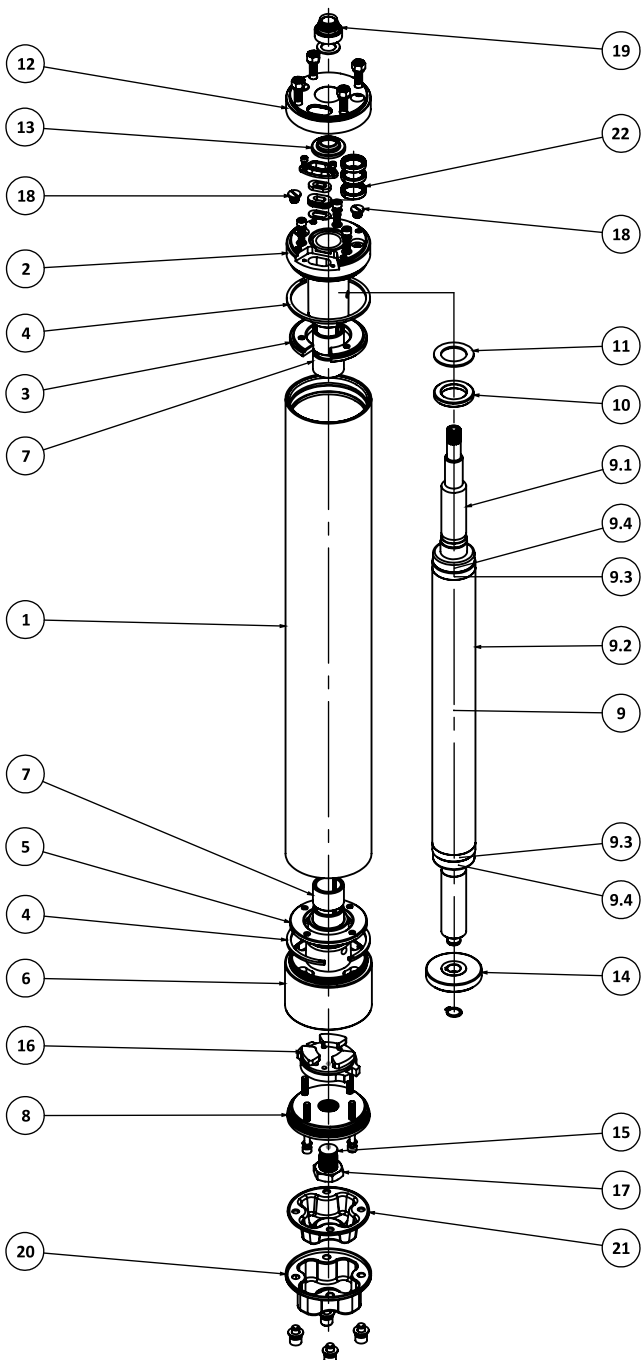

ITEM NO.	PART NAME	MATERIAL
1	Stator	-
2	Upper housing	Cast Iron FG200
3	Upper flange	Mild steel
4	Stator lock	Mild steel
5	Lower flange	Mild steel
6	Lower housing	Cast Iron FG200
7	Carbon bush	Carbon
8	Lower housing plate	Cast Iron FG200
9	Rotor	-
9.1	Shaft	SS AISI 431
9.2	Rotor Stamping stack	Electrical Steel
9.3	Copper ring	Copper
9.4	Balancing ring	Cast Iron FG200
10	SS thrust washer	SS AISI 410
11	PTFE thrust washer	PTFE
12	Upper cover	SS AISI 304
13	SS sand guard	SS AISI 304
14	Thrust bearing plate	Cast Iron+Carbon
15	Rockor support	SS AISI 410
16	Tilted bearing	Cast Iron+SS AISI 420
17	Rockor lock nut	SS AISI 410
18	Drain plug	SS
19	Sand slinger	NBR
20	Motor base	SS AISI 304
21	Diaphragm	NBR
22	Oil seal	-

Considering continuous product development, the information / description / specifications / illustrations are subjected to change without prior notice.

5" Submersible Motor

PRAKASH

Applications

- Domestic water supply to waterworks
- Irrigation in horticulture and agriculture
- Drip and sprinkler irrigation
- Pressure boosting application
- Water treatment
- Civil and Industrial application

Product feature

- Specially designed 5" motor for 4" NEMA extension.
- Easily rewindable (wet wound) induction motor with PVC/ Poly wrapped insulated winding.
- Water Lubricated Radial Bearing and High capacity Kingsbury type thrust bearing for 100% maintenance free operation.
- Corrosion resistance stainless steel stator jacket.
- Non-contaminating water filling design.
- High efficiency electrical design for low operation cost.
- Tropical zed design. (Lower winding temperature)
- Cable material according to drinking water regulation.
- All motors prefilled and 100% tested.
- Sand slinger for high performance in sand.

Specification

- 4" NEMA Flange with M8 Stud.
- Water temperature : Up to 45°C
- Minimum internal diameter of well : 5" Ø125mm.
- Power Range : 4 kW to 7.5 kW
- Power Supply : Three phase 380V-415V ±10%, 50 Hz.
- Insulation Class : F
- Protection Class : IP 68
- Max. No of starts per hour: 25
- Direction Of Rotation: counter clock wise facing shaft end (Rotation reversible for three phase motor)
- Standard motor with poly wrapped insulated winding
- Speed: 2900 rpm
- Pole: 2P
- Ambient temp. of 30°C with a min. Cooling flow : 4.0kW-7.5kW
- Installation position : vertical/Horizontal
- Duty: S1

Technical Data, 50Hz 380V-415V, 2900 RPM

Model	Motor Power		Max. Full Load (A)	Starting Current (A)	Full Load		Method of Start	Max. Down Thrust Load(N)	Torque (Nm)	Starting Torque (Nm)
	kW	HP			Eff. %	Power Factor				
PSMC125-5.5	4.0	5.5	10	43	69	0.7	D.O.L	10000	14	19
PSMC125-7.5	5.5	7.5	14	58	74	0.7	D.O.L	10000	19	28
PSMC125-10	7.5	10	18.5	78	75	0.7	D.O.L	10000	25	32

* D.O.L : Direct On Line



PSMC125 Motor

4 NOS. EQUISPACED
M8x1.25 PITCH
ON P.C.D 76.2 AT 90°

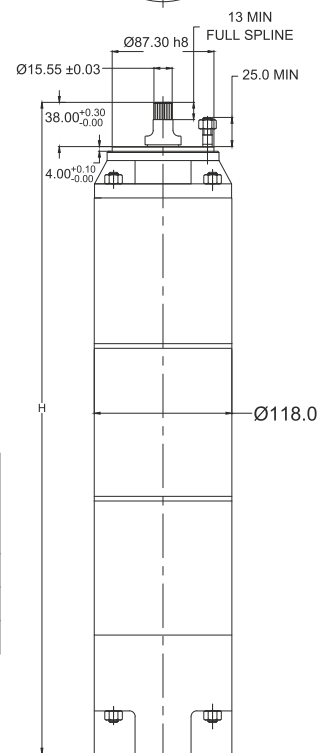
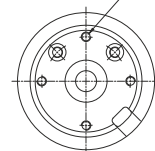

Packing Dimensions and Weight

Model	Motor Power		Max. Motor Dia (mm)	Height (mm)	Net. Weight Kg. (Approx.)	Cable Leadouts		
	kW	HP				CABLE SIZE SQ. MM		Cable Length in meter
						D.O.L	S/D	
PSMC125-5.5	4.0	5.5	118	709	31.0	4	2.5 + 2.5	3
PSMC125-7.5	5.5	7.5	118	779	39.7	4	2.5 + 2.5	3
PSMC125-10	7.5	10	118	859	45.5	4	2.5 + 2.5	5

Exploded View

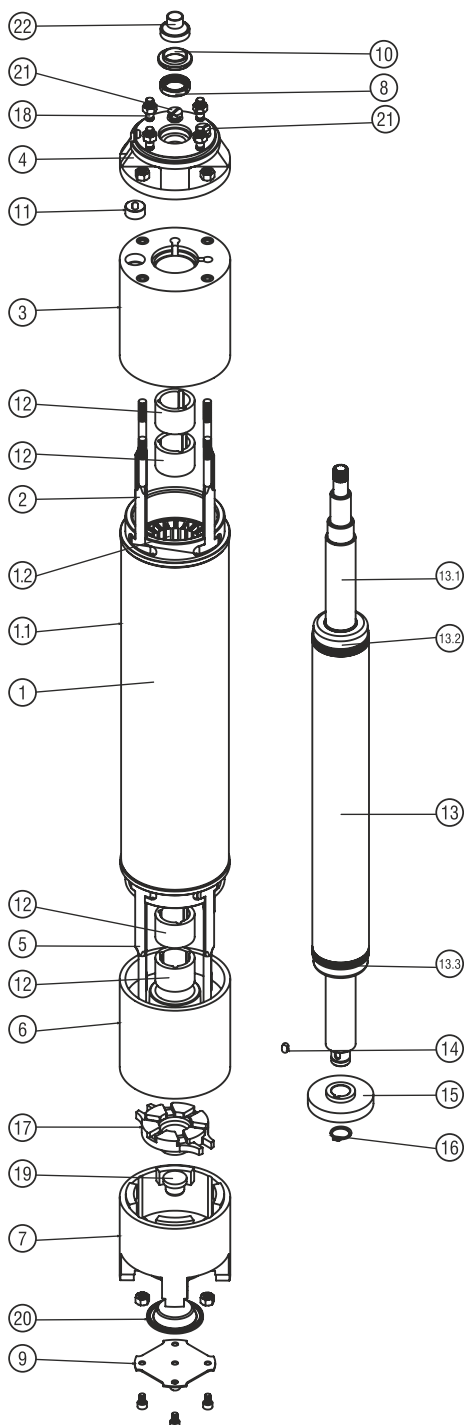

ITEM NO.	PART NAME	MATERIAL
1	Stator	-
1.1	Stator Tube	SS AISI 304
1.2	Stator Stamping	Electrical Steel
2	T-Bolt Upper	CED Coated Carbon Steel (En-8)
3	Upper Housing	Cast Iron FG200
4	Adaptor	Cast Iron FG200
5	T-Bolt Lower	CED Coated Carbon Steel (En-8)
6	Lower Housing	Cast Iron FG200
7	Motor Base	Cast Iron FG200
8	Oil Seal	NBR
9	Diaphragm Plate	SS AISI 304
10	Sand Cover	SS AISI 410
11	Grommet	NBR
12	Bearing Bush	LTB-4/Carbon
13	Rotor	-
13.1	Shaft	SS AISI 420 HT
13.2	Balancing Ring	Cast Iron FG200
13.3	Copper Ring	Copper
14	Bearing Key	SS AISI 410
15	Thrust Bearing Plate	Cast Iron FG260+ Carbon
16	Circlip	SS AISI 304/En-42
17	Thrust Bearing Base	Cast Iron FG260+SS AISI 420
18	M8 Stud	SS AISI 316L
19	Rocker Support	SS AISI 410
20	Diaphragm	NBR
21	Drain Plug	Brass
22	Sand Slinger	NBR

Considering continuous product development, the information / description / specifications / illustrations are subjected to change without prior notice.

Applications

- Domestic water supply to waterworks
- Irrigation in horticulture and agriculture
- Drip and sprinkler irrigation
- Pressure boosting application
- Water treatment
- Civil and Industrial application

Product feature

- Easily rewindable (wet wound) induction motor with PVC/ Poly wrapped insulated winding.
- Water Lubricated Radial Bearing and High capacity Kingsbury type thrust bearing for 100% maintenance free operation.
- Corrosion resistance stainless steel stator jacket.
- Non-contaminating water filling design.
- High efficiency electrical design for low operation cost.
- Tropical zed design. (Lower winding temperature)
- Cable material according to drinking water regulation.
- All motors Prefilled and 100% tested.
- Sand slinger for high performance in sand.

Specification

- 6" NEMA flange with M12 Stud.
- Water temperature : Up to 45°C
- Minimum internal diameter of well: 6" Ø150mm.
- Power Range : 4.0 kW to 45 kW
- Power Supply: Three phase 380V-415V $\pm 10\%$, 50 Hz.
- Insulation Class: F
- Protection Class : IP 68
- Max. No of starts per hour: 25
- Direction of Rotation : counter clock wise facing shaft end (Rotation reversible for three phase motor)
- Standard motor with Poly wrapped insulated winding
- Speed: 2900 rpm
- Pole: 2P
- Ambient temp. of 30°C with a min. Cooling flow: 4.0kW-15kW V=0.2m/s
18.5kW-45kW V=0.5m/s
- Installation position : Vertical/Horizontal
- Type of Duty : S1



PSMP150
Motor



PSMC150
Motor



PSMS150
Motor

6" Submersible Motor



Technical Data, 50Hz 380V-415V, 2900 RPM

Model	Motor Power		Max. Full Load (A)	Starting Current (A)	Full Load		Method of Start	Max. Down Thrust Load(N)	Torque (Nm)	Starting Torque (Nm)
	kW	HP			Eff. %	Power Factor				
PSMC150-5.5	4.0	5.5	10.5	43	76	0.7	D.O.L	15500	14	20
PSMP150-5.5										
PSMS150-5.5										
PSMC150-7.5	5.5	7.5	13	58	78	0.77	D.O.L	15500	18	24
PSMP150-7.5										
PSMS150-7.5										
PSMC150-10	7.5	10	16.5	72	82	0.75	D.O.L/SD	15500	25	27
PSMP150-10										
PSMS150-10										
PSMC150-12.5	9.3	12.5	21	84	82	0.79	D.O.L/SD	15500	31	35
PSMP150-12.5										
PSMS150-12.5										
PSMC150-15	11	15	24	103	83	0.8	D.O.L/SD	15500	37	43
PSMP150-15										
PSMS150-15										
PSMC150-17.5	13	17.5	29	118	83	0.8	D.O.L/SD	15500	43	51
PSMP150-17.5										
PSMS150-17.5										
PSMC150-20	15	20	33	148	83	0.81	D.O.L/SD	15500	49	62
PSMP150-20										
PSMS150-20										
PSMC150-25	18.5	25	42	188	83	0.81	D.O.L/SD	15500	61	98
PSMP150-25										
PSMS150-25										
PSMC150-30	22	30	49	225	83	0.81	D.O.L/SD	15500	74	118
PSMP150-30										
PSMS150-30										
PSMC150-35	26	35	56	270	83	0.82	D.O.L/SD	27500	86	138
PSMC150-40	30	40	67	355	83	0.82	D.O.L/SD	27500	98	196
PSMC150-50	37	50	80	421	82	0.83	D.O.L/SD	27500	123	245
PSMC150-60	45	60	93	465	82	0.83	D.O.L/SD	27500	150	396

* D.O.L connection single cable
 * S/D connection double cable

Packing Dimensions and Weight

Model	Motor Power		Max. Motor Dia (mm)	Height (mm)	Net. Weight Kg. (Approx.)	Cable Leadouts		
	kW	HP				CABLE SIZE SQ. MM		Cable Length in meter
						D.O.L	S/D	
PSMC150-5.5	4.0	5.5	144	702	47	6	6 + 6	3
PSMC150-7.5	5.5	7.5	144	777	55	6	6 + 6	3
PSMC150-10	7.5	10	144	817	60.5	6	6 + 6	3
PSMC150-12.5	9.3	12.5	144	857	64.5	6	6 + 6	3
PSMC150-15	11	15	144	877	66.2	6	6 + 6	3
PSMC150-17.5	13	17.5	144	937	72.5	6	6 + 6	3
PSMC150-20	15	20	144	977	77.5	6	6 + 6	3
PSMC150-25	18.5	25	144	1027	82.5	6	6 + 6	3
PSMC150-30	22	30	144	1102	91.5	6	6 + 6	4
PSMC150-35	26	35	144	1177	97	10	10 + 10	5
PSMC150-40	30	40	144	1297	107	10	10 + 10	5
PSMC150-50	37	50	144	1397	117	10	10 + 10	5
PSMC150-60	45	60	144	1497	128	16	10 + 10	5

* D.O.L connection single cable
 * S/D connection double cable

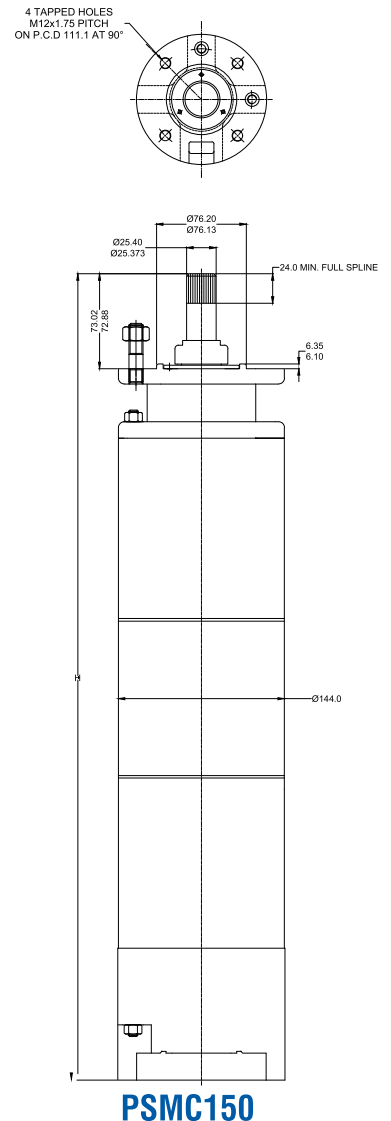

Packing Dimensions and Weight

Model	Motor Power		Max. Motor Dia (mm)	HEIGHT (mm)	Net. Weight kg(Approx.)	Cable Leadouts		
	kW	HP				Cable Size SQ. MM		Cable Length
						D.O.L	S/D	
PSMP150-5.5	4.0	5.5	142	670	40	6	6 + 6	3
PSMP150-7.5	5.5	7.5	142	745	48	6	6 + 6	3
PSMP150-10	7.5	10	142	785	53	6	6 + 6	3
PSMP150-12.5	9.3	12.5	142	825	57	6	6 + 6	3
PSMP150-15	11	15	142	845	59	6	6 + 6	3
PSMP150-17.5	13	17.5	142	905	66	6	6 + 6	3
PSMP150-20	15	20	142	945	70	6	6 + 6	3
PSMP150-25	18.5	25	142	995	75	6	6 + 6	3
PSMP150-30	22	30	142	1070	84	6	6 + 6	4

* D.O.L connection single cable

* S/D connection double cable

Packing Dimensions and Weight

Model	Motor Power		Max. Motor Dia (mm)	HEIGHT (mm)	Net. Weight kg(Approx.)	Cable Leadouts		
	kW	HP				Cable Size SQ. MM		Cable Length
						D.O.L	S/D	
PSMS150-5.5	4.0	5.5	142	660	40	6	6 + 6	3
PSMS150-7.5	5.5	7.5	142	735	48	6	6 + 6	3
PSMS150-10	7.5	10	142	775	53	6	6 + 6	3
PSMS150-12.5	9.3	12.5	142	815	57	6	6 + 6	3
PSMS150-15	11	15	142	835	59	6	6 + 6	3
PSMS150-17.5	13	17.5	142	895	66	6	6 + 6	3
PSMS150-20	15	20	142	935	70	6	6 + 6	3
PSMS150-25	18.5	25	142	985	75	6	6 + 6	3
PSMS150-30	22	30	142	1060	84	6	6 + 6	4

* D.O.L connection single cable

* S/D connection double cable

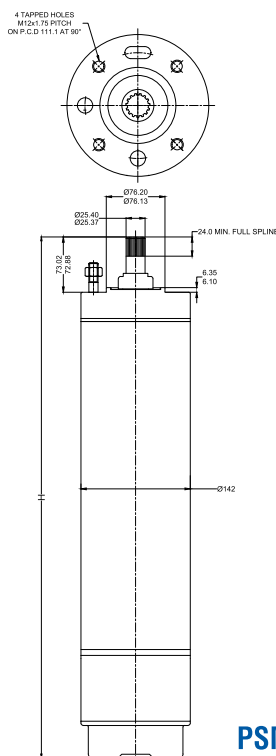

PSMS150 & PSMP150 MOTOR

6" Submersible Motor



Exploded View (PSMC150)

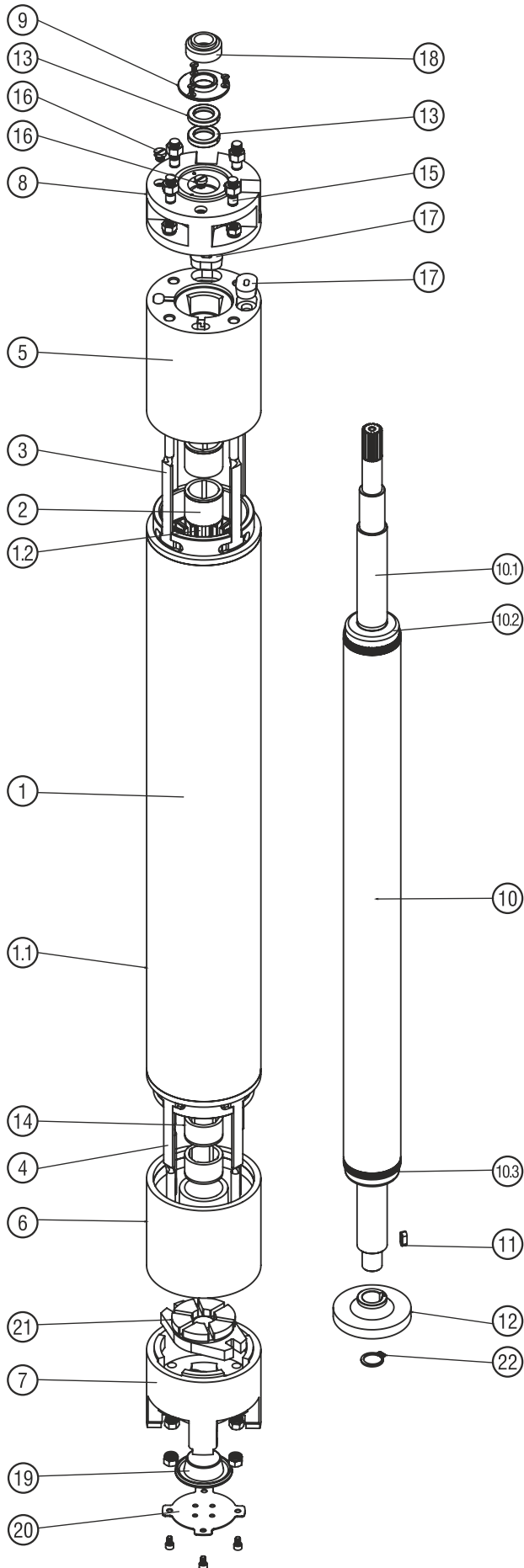

ITEM NO.	PART NAME	MATERIAL
1	Stator	-
1.1	Stator Tube	SS AISI 304
1.2	Stator Stamping	Electrical Steel
2	Bearing Bush Upper	LTB-4/Carbon
3	T-Bolt Upper	CED Coated Carbon Steel (EN-8)
4	T-Bolt Lower	CED Coated Carbon Steel (EN-8)
5	Upper Housing	Cast Iron FG200
6	Lower Housing	Cast Iron FG200
7	Motor Base	Cast Iron FG200
8	Adaptor	Cast Iron FG200
9	Sand Cover	SS AISI 410
10	Rotor	-
10.1	Shaft	SS AISI 420 HT/SS AISI 431
10.2	Balancing Ring	Cast Iron FG200
10.3	Copper Ring	Copper
11	Bearing Key	SS AISI 410
12	Thrust Bearing Plate	Cast iron FG260+Carbon
13	Oil Seal	NBR
14	Bearing Bush Lower	LTB-4/Carbon
15	M12 Stud	SS AISI 316L
16	Drain Plug	Brass
17	Grommet	NBR
18	Sand Slinger	NBR
19	Diaphragm	NBR
20	Diaphragm Plate	SS AISI 304
21	Thrust Bearing Base	SS AISI 420+ Cast iron FG260
22	Circlip	SS AISI 304/EN-42

Considering continuous product development, the information / description / specifications / illustrations are subjected to change without prior notice.

6" Submersible Motor



Exploded View (PSMP150)

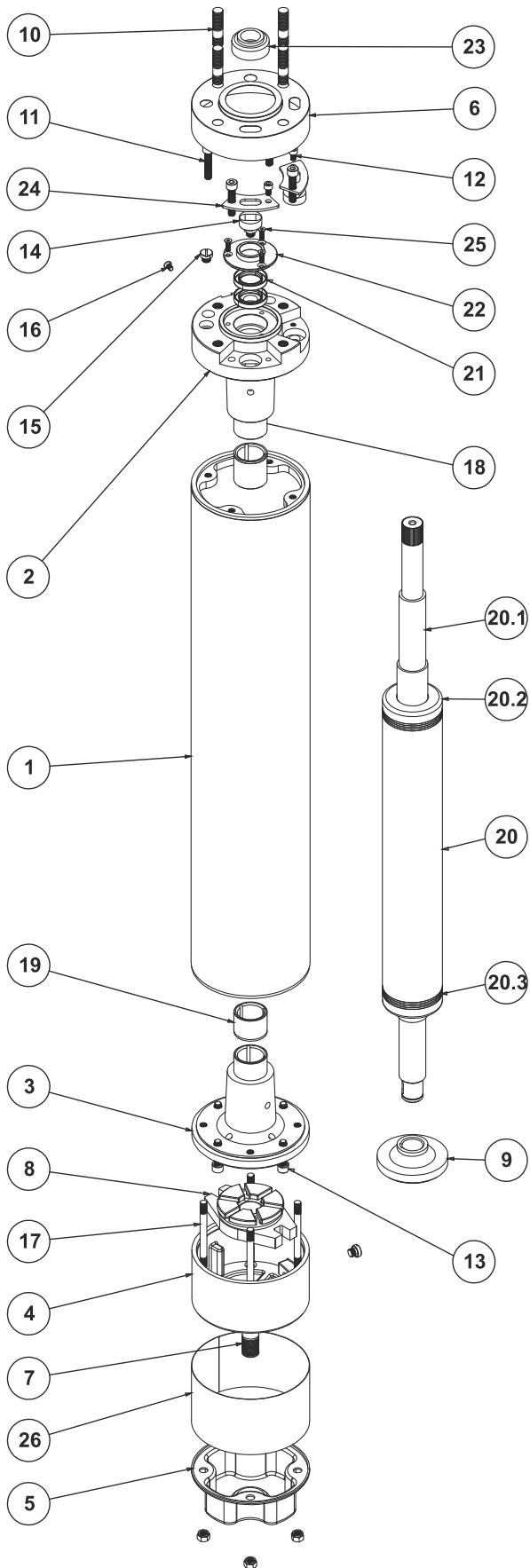

ITEM NO.	PART NAME	MATERIAL
1	Stator	-
2	Upper housing	Cast Iron FG200
3	Lower housing	Cast Iron FG200
4	Thrust bearing body	Cast Iron FG200
5	Motor base	SS AISI304
6	Upper Jacket	SS AISI304
7	Rocker Support	SS AISI410
8	Thrust bearing base	Cast Iron FG260+SS AISI420
9	Thrust bearing plate	Cast Iron FG260+ Carbon
10	M12X50 stud	SS AISI 304 / SS AISI 316
11	M8 x 40 Allen bolt	SS AISI304
12	M6 x 10 Allen bolt	SS AISI304
13	M8 x 35 Allen bolt	SS AISI304
14	Grommet	NBR
15	Drain plug	SS
16	M5 x 10 earthing screw	SS AISI304
17	Lower stud	SS AISI304
18	32X40X40 bearing bush (Upper)	LTB-4/Carbon
19	32X40X30 bearing bush (Lower)	LTB-4/Carbon
20	Rotor	-
20.1	Shaft	SS AISI420/SS AISI431
20.2	Balancing ring	Cast Iron FG200
20.3	Copper ring	Copper
21	Oil seal	NBR
22	Sand cover	SS AISI304
23	Sand Slinger	NBR
24	Cable clip	SS AISI304
25	Allen CSK	SS AISI304
26	Lower jacket	SS AISI304

Considering continuous product development, the information / description / specifications / illustrations are subjected to change without prior notice.

6" Submersible Motor



Exploded View (PSMS150)

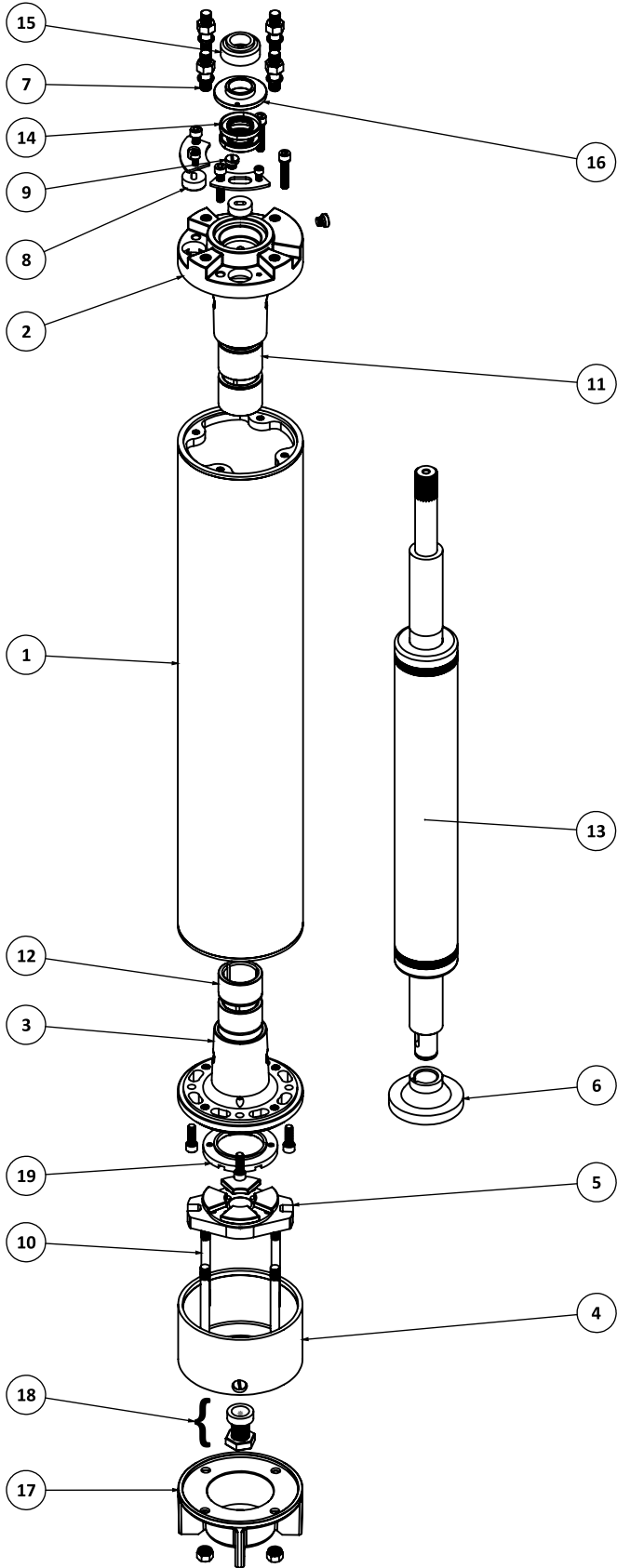

ITEM NO.	PART NAME	MATERIAL	QTY.
1	Stator		1
2	Upper housing	SS AISI 304	1
3	Lower housing	SS AISI 304	1
4	Thrust bearing body	SS AISI 304	1
5	Tilted segment base	CI FG 260 + SS AISI420	1
6	Thrust plate	CI Fg260 + CARBON	1
7	M12 stud	SS AISI 304	4
8	Grommet	NBR	2
9	Drain plug	BRASS	3
10	Lower stud	SS AISI 304	4
11	Upper bearing bush	CARBON	2
12	Lower bearing bush	CARBON	2
13	Rotor		1
14	Oilseal	NBR	2
15	Sand Slinger	NBR	1
16	Sand guard	SS AISI 410	1
17	Motor base	SS AISI 304	1
18	Rockor arragement	SS AISI 410	1
19	Back thrust counter	LTB-5	1

Applications

- Domestic water supply to waterworks
- Irrigation in horticulture and agriculture
- Drip and sprinkler irrigation
- Pressure boosting application
- Water treatment
- Civil and Industrial application

Product Feature

- Easily rewindable (wet wound) induction motor with PVC/ Poly wrapped insulated winding.
- Water Lubricated Radial Bearing and High capacity Kingsbury type thrust bearing for 100% maintenance free operation.
- Corrosion resistance stainless steel stator jacket.
- Non-contaminating water filling design.
- High efficiency electrical design for low operation cost.
- Tropical zed design. (Lower winding temperature)
- Cable material according to drinking water regulation.
- All motors prefilled and 100% tested.
- Sand slinger for high performance in sand.
- Specially designed thrust bearing to withstand high axial thrust loads
- Leakage protection with Mechanical seal (PSMP-200)
- Leakage protection with double oil seal (PSMC-200)
- Pressure equalizing forward valve/reverse valve
- Sand fighter sealing design with Mechanical seal and Oil seal
- Pressure equalizing diaphragm

Specification

- 8" NEMA flange with M16 Stud.
- Water temperature : Up to 45°C
- Minimum internal diameter of well: 8" Ø200mm.
- Power Range: 22 kW to 93 kW
- Power supply: Three Phase, 380 V - 415 V \pm 10%, 50Hz
- Insulation Class: F
- Protection Class : IP 68
- Max. No of starts per hour: 20
- Direction of Rotation: Counter clock wise facing shaft end (Rotation reversible for three phase motor)
- Standard motor with triple coated poly wrapped insulated winding wire.
- Speed: 2900 rpm
- Pole: 2P
- Ambient temp. of 30°C with a min. Cooling flow: 0.5m/s
- Installation position: Vertical/Horizontal
- Type of Duty: S1



PSMC200



PSMP200

Considering continuous product development, the information / description / specifications / illustrations are subjected to change without prior notice.

8" Submersible Motor

PRAKASH

Technical Data, 50Hz 380V-415V, 2900 RPM

Model	Motor Power		Max. Full Load (A)	Starting Current (A)	Full Load		Method of Start	Max. Down Thrust Load(N)	Torque (Nm)	Starting Torque (Nm)
	kW	HP			Eff. %	Power Factor				
PSMP200-30	22	30	47	220	84	0.86	D.O.L/SD	45500	73	120
PSMC200-30										
PSMP200-35	26	35	54	280	85	0.85	D.O.L/SD	45500	86	145
PSMC200-35										
PSMP200-40	30	40	60	330	85	0.85	D.O.L/SD	45500	101	168
PSMC200-40										
PSMP200-50	37	50	80	400	86	0.85	D.O.L/SD	45500	122	200
PSMC200-50										
PSMP200-60	45	60	92	520	86	0.85	D.O.L/SD	45500	149	268
PSMC200-60										
PSMP200-75	55	75	112	660	87	0.85	D.O.L/SD	45500	180	370
PSMC200-75										
PSMP200-85	63	85	126	720	87	0.85	D.O.L/SD	45500	206	410
PSMC200-85										
PSMP200-100	75	100	151	930	88	0.86	D.O.L/SD	45500	246	520
PSMC200-100										
PSMP200-125	93	125	190	1250	88	0.86	D.O.L/SD	45500	306	680
PSMC200-125										

* D.O.L : Direct On Line

* S/D : Star - Delta

Packing Dimensions and Weight

Model	Motor Power		Max. Motor Dia (mm)	Height (mm)	Net. Weight Kg. (Approx.)	Cable Leadouts		
	kW	HP				CABLE SIZE SQ. MM		Cable Length in meter
						D.O.L	S/D	
PSMP200-30	22	30	187	1120	140	6	6+6	3
PSMP200-35	26	35	187	1170	150	10	6+6	5
PSMP200-40	30	40	187	1240	155	10	6+6	5
PSMP200-50	37	50	187	1315	169	10	10+10	5
PSMP200-60	45	60	187	1390	173	16	10+10	5
PSMP200-75	55	75	187	1490	196	25	16+16	5
PSMP200-85	63	85	187	1540	208	25	16+16	5
PSMP200-100	75	100	187	1590	218	35	16+16	5
PSMP200-125	93	125	187	1690	230	35	25+25	5

* D.O.L : Connection Single Cable

* S/D : Connection Double Cable

Packing Dimensions and Weight

Model	Motor Power		Max. Motor Dia (mm)	Height (mm)	Net. Weight Kg. (Approx.)	Cable Leadouts		
	kW	HP				CABLE SIZE SQ. MM		Cable Length in meter
						D.O.L	S/D	
PSMC200-30	22	30	187	1169	166	6	6+6	3
PSMC200-35	26	35	187	1219	161	10	6+6	5
PSMC200-40	30	40	187	1259	181	10	6+6	5
PSMC200-50	37	50	187	1359	195	10	10+10	5
PSMC200-60	45	60	187	1409	203	16	10+10	5
PSMC200-75	56	75	187	1509	214	25	16+16	5
PSMC200-85	63	85	187	1609	231	25	16+16	5
PSMC200-100	75	100	187/195	1684	248	35	16+16	5
PSMC200-125	93	125	187/195	1749	255	35	25+25	5

* D.O.L connection single cable

* SD connection double cable

4 NOS EQUISPACED
M16 x 2 Pitch
ON P.C.D 152.4 AT 90°

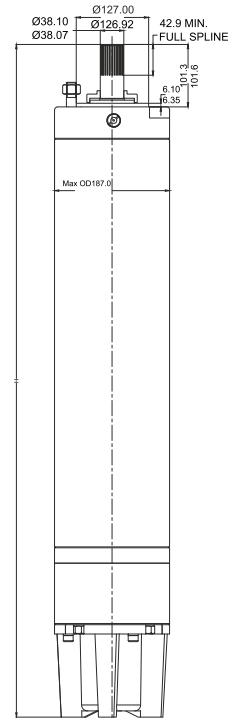
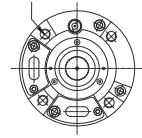

PSMP200

4 NOS EQUISPACED
M16 x 2 PITCH
ON P.C.D 152.4 AT 90°

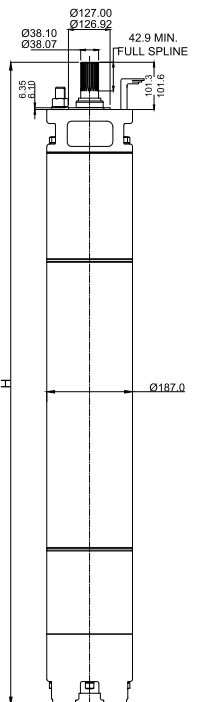

PSMC200

8" Submersible Motor



Exploded View (PSMP200)

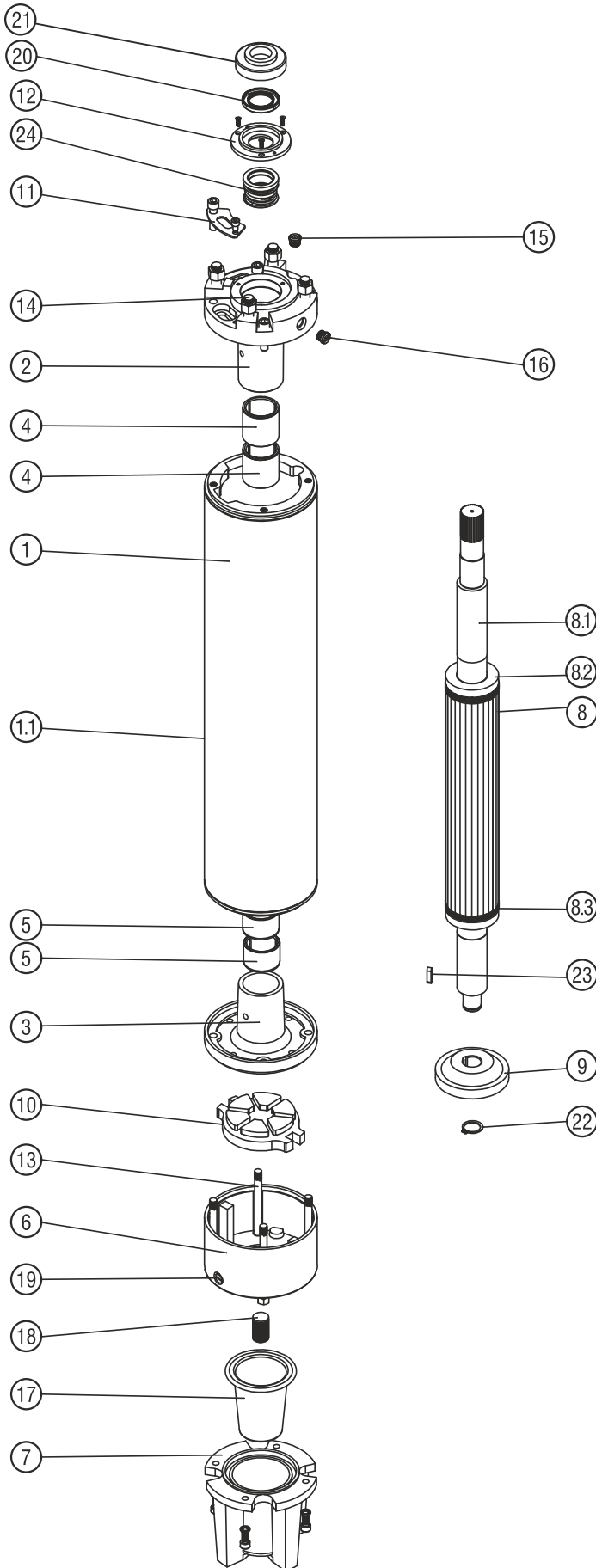

ITEM NO.	PART NAME	MATERIAL
1	Stator	-
1.1	Stator Tube	SS AISI 304
2	Upper Housing	Cast Iron FG200
3	Lower Housing	Cast Iron FG200
4	Upper Housing Bush	LTB-4/Carbon
5	Lower Housing Bush	LTB-4/Carbon
6	Thrust Bearing Body	Cast Iron FG200
7	Motor Base	Cast Iron FG200
8	Rotor	-
8.1	Shaft	SS AISI 420 HT/SS AISI 431
8.2	Balancing Ring	Cast Iron FG200
8.3	Copper Ring	Copper
9	Thrust Bearing Plate	Cast Iron FG260+ Carbon
10	Thrust Bearing Base	Cast Iron FG260+ SS AISI 420
11	Cable Clip	SS AISI 304
12	Seal Guard	SS AISI 304
13	Lower Tie Rod	SS AISI 304
14	M16 Stud	SS AISI 304/SS AISI 316
15	Water Filling Plug	Brass
16	Pressure Release Valve	Brass
17	Diaphragm	NBR
18	Rocker Support	SS AISI 410
19	Drain Plug	Brass
20	Oil Seal	NBR
21	Sand Slinger	NBR
22	Circlip	EN42/SS AISI 304
23	Thrust Bearing Key	SS AISI 410
24	Mechanical Seal	NBR Ceramic-Carbon/SIC-SIC

Considering continuous product development, the information / description / specifications / illustrations are subjected to change without prior notice.

8" Submersible Motor

Exploded View (PSMC200)

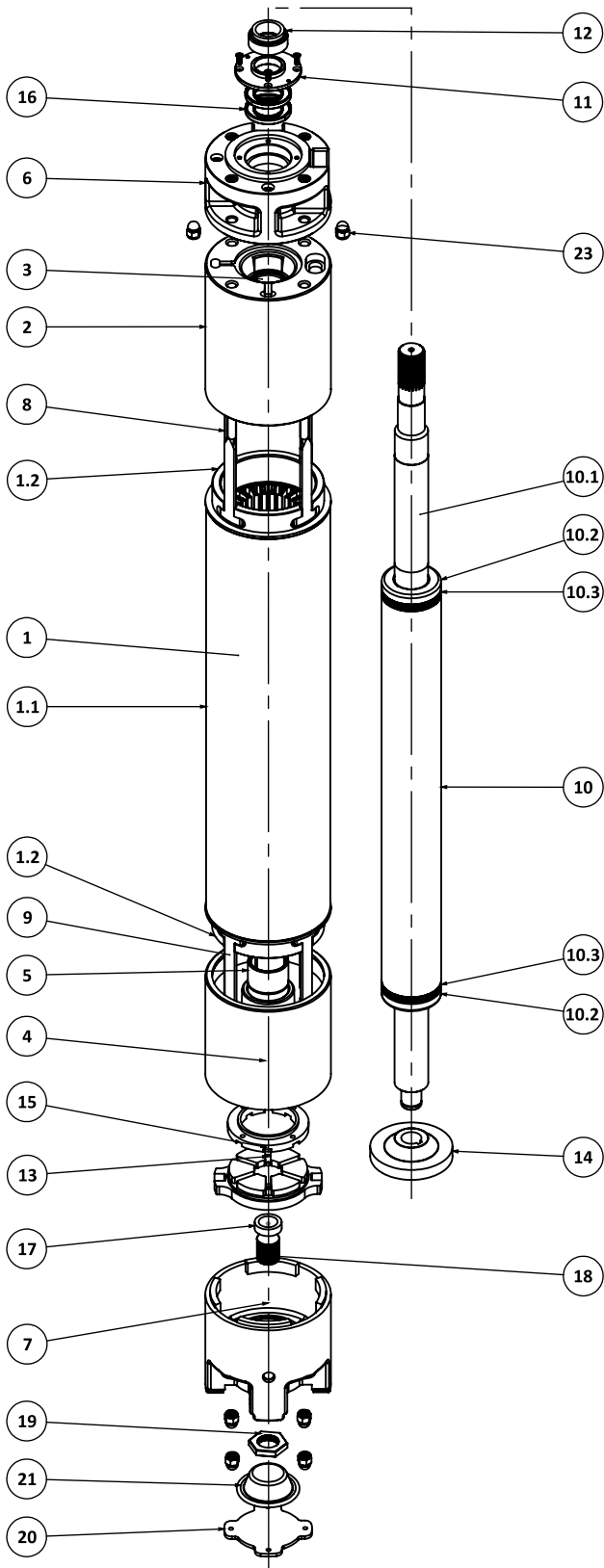

ITEM NO.	PART NAME	MATERIAL
1	Stator	-
1.1	Stator tube	SS AISI304
1.2	End Ring	En8
2	Upper housing	Cast Iron FG200
3	Upper housing bush	LTB-4/Carbon
4	Lower housing	Cast Iron FG200
5	Lower housing bush	LTB-4/Carbon
6	Adaptor	Cast Iron FG200
7	Motor base	Cast Iron FG200
8	T-Bolt upper	CED Coated carbon steel (EN-8)
9	T-Bolt lower	CED Coated carbon steel (EN-8)
10	Rotor	-
10.1	Shaft	SS AISI410/SS AISI420
10.2	Balacing ring	Cast Iron FG200
10.3	Copper ring	Copper
11	Sand gaurd	SS AISI410
12	Sand slinger	NBR
13	Thrust Bearing base (titing type)	Cast Iron FG260+SS AISI420
14	Thrust bearing plate	Cast Iron FG260+ Carbon
15	Back thust counter	TEFLON/BRONZE
16	Oil seal	NBR
17	Concave rocker	SS AISI410
18	Flat rocker support	SS AISI410
19	Rocker support Nut	SS AISI410
20	Diaphragm plate	SS AISI304
21	Diaphragm	NBR

ELECTRICAL CONNECTION INFORMATION

D.O.L CONNECTION

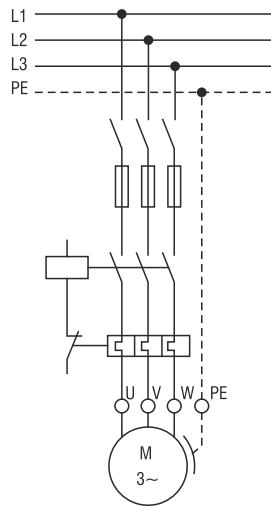

STAR - DELTA CONNECTION

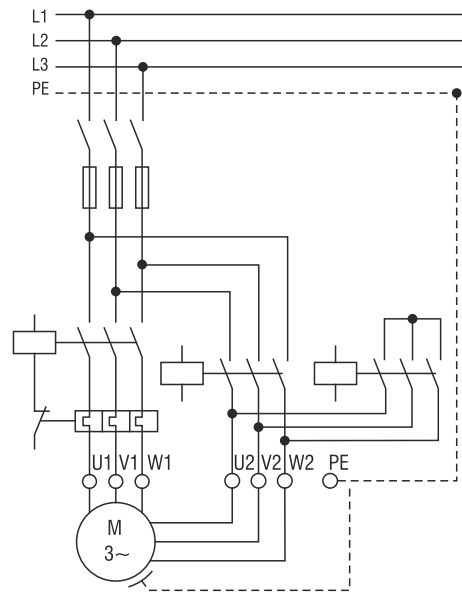

U	V	W	PE
RED	YELLOW	BLUE	GREEN

MODEL IDENTIFICATION CODE

P S M C 150-10

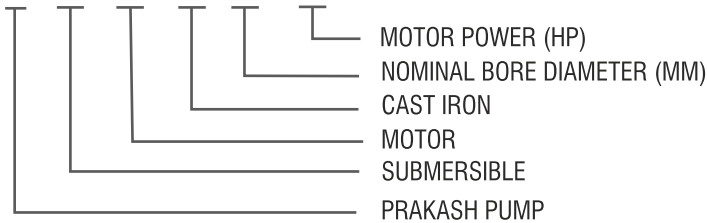

P S M P 150-10

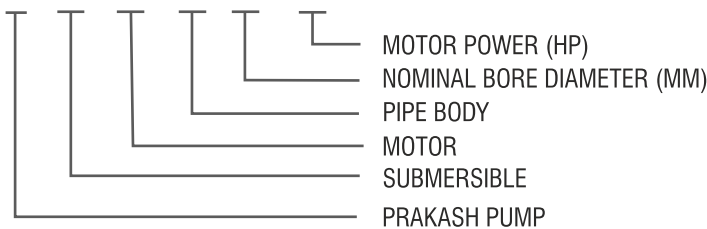

P S M S 150-10

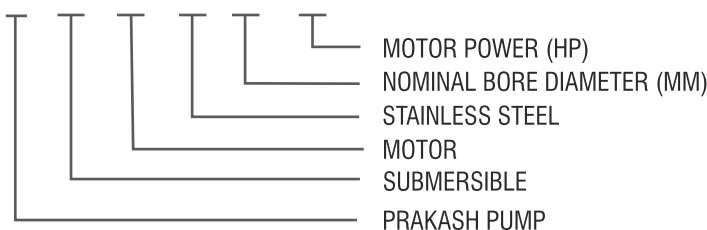

POWER CABLE CONNECTION

Connection of the power cable that will be used along the well and until the control panel with the power cable on the motor must be done very carefully and by the professionals only. If the insulation after connection is not done properly; short circuit might happen during the connection area is in the water.

Insulation of each cable should be stripped only as far as necessary to provide room for a stake type connector. Each individual joint should be taped with PVC tape, using two layers by wrapping tightly for eliminating airspaces as much as possible.

Total thickness of tape should be no less than the thickness of the cable insulation in order to prevent the smashing of the cables when the pump is lowered in the well.

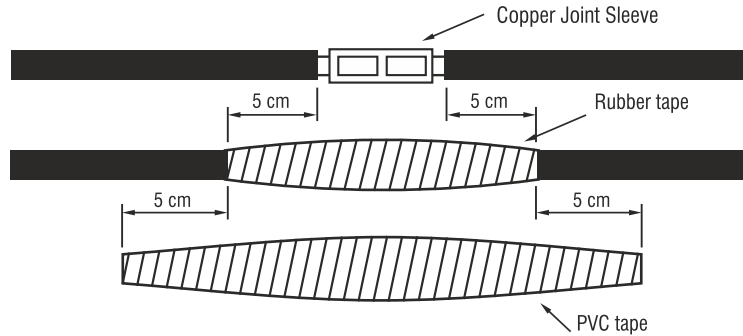

Cable Selection Chart, 415V, 50Hz, Three Phazse D.O.L

HP	Cable Sizes								
	3x1.5	3x2.5	3x4	3x6	3x10	3x16	3x25	3x35	3x50
5.5	65	140	270	370	500				
7.5	48	80	140	270	420	500			
10			102	200	320	500			
12.5				140	220	370	520		
15				60	220	370	500		
17.5				60	180	270	420	500	
20				80	180	270	420	500	
25					140	220	320	470	500
30					110	180	270	370	500
35						140	220	270	420
40						140	220	270	420
50						110	180	320	420
60							140	200	320
75							110	140	220
85								120	180
100									132
125									132

STAR - DELTA

HP	Cable Sizes								
	3x1.5	3x2.5	3x4	3x6	3x10	3x16	3x25	3x35	3x50
5.5	97	161	258	388	646				
7.5	60	140	270	420	500				
10		110	180	270	470	500			
12.5			128	200	320	500			
15			128	200	320	500			
17.5			100	140	270	420	500		
20			100	140	270	420	500		
25				110	200	320	500		
30				100	180	270	420	500	
35					128	200	320	420	500
40					128	200	320	420	500
50					100	140	270	320	500
60					90	128	220	270	420
75						110	180	220	370
85						90	128	180	270
100						90	128	180	270
125							100	140	200

PRAKASH

Office in India

PRAKASH PUMP

Survey No. 479, Opp. Supreme Estate-1, Zak Kadadara Road, Vill. - Kadadara,
Tal. Dahegam, Gandhinagar, Gujarat 382305 INDIA E-mail: sale@prakashpump.com

Distributor Office for Middle East

PRAKASH PUMP EST

P.O. Box: 20973 Industrial Area Al Ain (United Arab Emirates)
Tel.: +971 3 7222733 Mob.: +971 50 6731283 E-mail: sale@prakashpump.com

Distributor Office for Oman

GLOBAL EQUIPMENT MATERIAL CO. LLC

P.O. Box. 227, Postal Code: 320 Nakhal Road, Barka (Sultanate of Oman)
Tel.: +968 26883982 Mob.: +968 94584686 E-mail: oman@prakashpump.com

Distributor Office for Saudi Arabia

PRAKASH PUMP INDUSTRY

P.O. Box 14327, Bldg. 3616, Al Marwah 6447, Al Mishaal Riyadh City, (Kingdoms of Saudi Arabia)
Sulay Exit 18. Mobile: +966 539811109 Email: saudi@prakashpump.com

Factory Address

PANJI ENGINEERING PVT LTD

Survey No. 479, Opp. Supreme Estate-1, Zak Kadadara Road, Vill. - Kadadara,
Tal. Dahegam, Gandhinagar, Gujarat 382305 INDIA E-mail: sale@prakashpump.com



To get
Quotation by email



PRAKASHPUMPEST

These images given are only for illustration purpose
for further details contact the sales team at
sale@prakashpump.com / oman@prakashpump.com
/ saudi@prakashpump.com



To get
Website

